

Data Sheet - Series 170 Subminiature Position Transducer

Subminiature Size, Flexible Mounting

Shaded characteristics are verified during production and test. All others are for REFERENCE and information only.

Key Features

1. 2.0-Inch (51-mm) Maximum Travel
2. Analog Signal Using Precision Conductive Plastic Potentiometer
3. AccuTrak™ Grooved Drum for Enhanced Repeatability
4. Bearing-Mounted Rotating Components
5. Optional Flexible Mounting Bases
6. Integrated Left-Hand and Right-Hand Mounting
7. DirectConnect™ Sensor-To-Drum Technology = Zero Backlash, No Torsion Springs or Clutches



Potentiometer Specifications

Potentiometer Type	1-turn, precision, conductive plastic
Resistance: Value, Tolerance	5K ohms, $\pm 10\%$
Travel: Electrical, Mechanical	340°, 340° min
Mechanical Life	100 million shaft revolutions min
Output Signal	analog signal from 0 to supply voltage (voltage divider circuit)
Power Rating	1.0 W at 158° F (70° C)
Supply Current	12 mA max
Supply Voltage	35 VDC max (using voltage divider circuit)
Independent Linearity Error	$\pm 0.5\%$ max per VRCI-P-100A
Output Smoothness	0.1% max
Insulation Resistance	1000 Mohms at 500 VDC min
Dielectric Strength	1000 VDC min
Resolution	infinite signal
Operating Temperature	-85° to +257° F (-65° to +125° C)
Shock, Vibration	100 g for 6 ms, 10 to 2000 Hz at 15 g per Mil-R-39023
Temperature Coefficient	± 400 ppm/°C max

Other Specifications

Case Materials	precision-machined anodized 2024 aluminum
Displacement Cable	0.018-inch (0.46-mm) dia., 7-by-7 stranded stainless steel, 40-lb (177-N) min breaking strength
Displacement Cable Hardware	1 each of 300196 loop sleeve , 300292 copper sleeve , 300688 ball-end plug , 300495 pull ring , 160026 brass swivel , and 301003 nickel swivel ; all items provided uncrimped
Nominal Mass	1 oz (28 g)
Displacement Cable Tension and max Cable Acceleration (Nominal): Opt. 1	1.5 oz 0.4 N min 4 oz 1.1 N max 20 g max

Displacement Cable Tension and max Cable Acceleration (Nominal): Opt. 2	1.5 oz 0.4 N min 12 oz 3.3 N max 40 g max
Environmental Protection	NEMA 3S / IP 54, DO-160D (ED-14D) Env. Cat. E1E1ABSHXFDXSAXXXXXXXXXXX

Model Numbers and Ordering Codes

170-0161-ab	position transducer (2.0-inch (51-mm) range)
Example: 170-0161-1N (cable tension: -010, no base)	

Variable	Value	Description
a	1	cable tension: -010
a	2	cable tension: -020
b	N	no base
b	B	base: L (150/170 only); pn 150015

Drawing

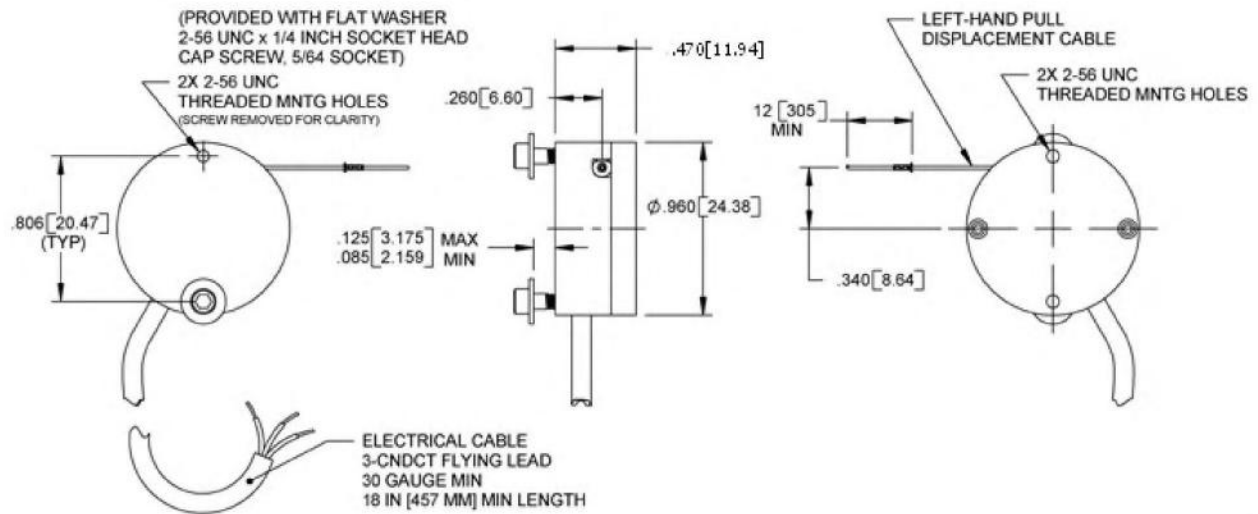

Electrical Connection for Increasing Output with Displacement Cable Extraction	
Wire Color	Signal
black	input, V+
white	output, signal, S+
red	ground, common, V-, S-

For crimping of hardware to displacement cable, consider the [160001-01 installation kit](#).

Need something not shown? Complete a [Custom Solution Request](#).

All dimensions are REFERENCE and are in inches [mm] • Data Sheet Series 170 Rev.-

Privacy Policy Privacy Policy

[Firstmark Controls](#) • info@Firstmarkcontrols.com
An ISO9001:2000/AS9100B-Compliant Company
1176 Telecom Drive • Creedmoor, NC 27522 USA

All specifications subject to change without notice.
© 1996-2010 Firstmark Controls All rights reserved.