

DQ-1000A Frequency to Analog Interface User Guide

Overview

The Loadstar Sensors DQ-1000 Single Channel Frequency Interface provides a simple and convenient way for users to convert the frequency output of an iLoad Mini sensor to either a USB digital output (DQ-1000U) or analog outputs (DQ-1000A) of 0–5 V DC and 0–20 mV. When ordered together with an iLoad Mini sensor, the DQ-1000A can be calibrated to the sensor to enable direct 0.5 V to 4.5V or compatibility with legacy displays that accept 2 mV/V input.

Instructions for Use

Loadstar Sensors' Model DQ-1000 Single Channel Frequency-to-Analog Interface takes the frequency output from an iLoad Mini sensor and converts it to two different analog outputs: a 20 mV/V ratiometric output and a 0–5 V DC analog output.

Notes

1. Note that the DC_{out-}, the 20 mV- and the EXC- are all connected to the common ground.
2. If you are using the ratiometric 20 mV/V output, the recommended excitation voltage is +10V. The minimum voltage is +5V.
3. The actual range of voltage for the 0–5V DC output is from approximately 0.5V (at no load) to 4.5V at full load. The relationship between the load and voltage is on a calibration chart provided with the sensor and DQ-1000A.

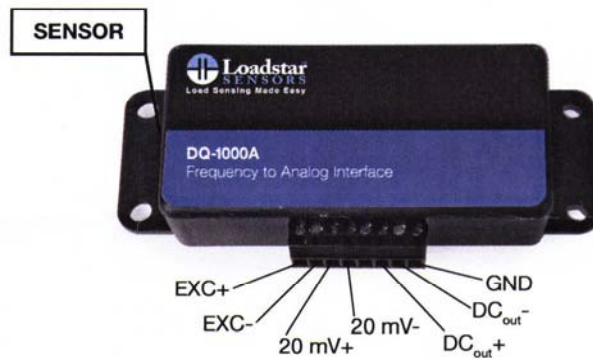

The picture (left) shows the ports of the Frequency-to-Analog Interface.

Dimensions and Mounting Diagram

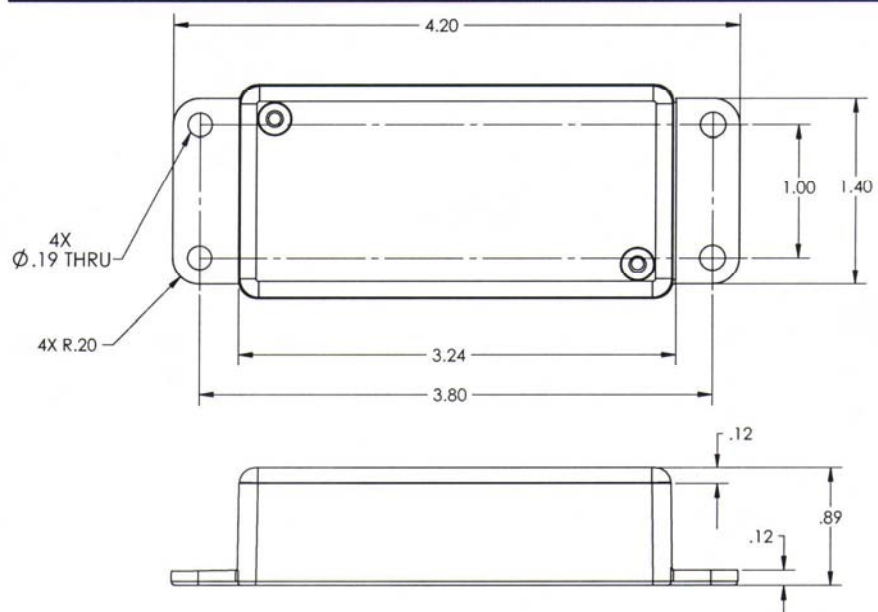

Prodyamics GmbH
Adalbertstr. 63
60486 Frankfurt
Fon: 069-70790850
Fax: 069-70790851

This specification sheet is solely for the information and exclusive use of the original addressee and is not to be divulged in whole or in part by any firm or individual without the express permission of Loadstar Sensors, Inc. The products described herein are not released for sale and may not perform as specified in all respects.