

# Data Sheet – Series 6 Miniature Position Transducers

## With FlexSignal™ Integrated Signal Conditioning

### Key Features

1. 85-Inch (2159-mm) Maximum Travel (Model 62)
2. Choice of FlexSignal™ Analog and Digital Output Signals (Factory Set)
  - ◆ Voltage Divider
  - ◆ Low-Level Bridge (B Circuit / Strain Gage Compatible)
  - ◆ Voltage Conditioner
    - ◇ Flexible User Adjustable Zero and Span Controls
    - ◇ 0–5 VDC, 0–10 VDC, ±5 VDC, ±10 VDC, and more
  - ◆ 4–20 mA (Current Loop)
  - ◆ Quadrature (Standard- and High-Resolution Digital)
3. AccuTrak™ Threaded Drum For Enhanced Repeatability
4. DirectConnect™ Sensor-To-Drum Technology = Zero Backlash, No Torsion Springs or Clutches
5. NEMA 4 / IP 66 Environmental Protection
6. Flexible Mounting Bases
7. Industrial Operating Temperature Ranges
8. Choice of Electrical Terminations: MIL-C-5015, DIN 45326, Lemo, flying leads

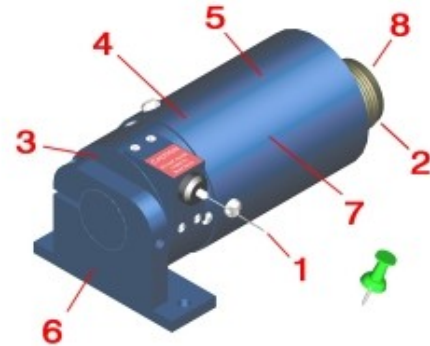

### Electrical Outputs – Voltage Divider

VOLTAGE DIVIDER (hybrid or conductive plastic precision potentiometer)

Item	1-turn sensor	3- and 5-turn sensors
Resistance: Value, Tolerance	5K ohms, ±10%	5K ohms, ±10%
Travel: Electrical	340°	1080° (3-turn), 1800° (5-turn)
Travel: Mechanical	360° continuous	1080° (3-turn), 1800° (5-turn) (+15° -0°)
Mechanical Life	5 million shaft revolutions min	5 million shaft revolutions min
Power Rating	1.0 W at 158° F (70° C); 50 VDC / 12 mA max	2.0 W at 158° F (70° C); 50 VDC / 12 mA max
Independent Linearity Error	±0.5% max per VRCI-P-100A	±0.25% max per VRCI-P-100A
Output Smoothness	0.1% max	0.051% max
Insulation Resistance	1000 Mohms min at 750 Vrms	1000 Mohms min at 750 Vrms
Dielectric Strength	750 Vrms min	1000 Vrms min
Resolution	infinite signal	infinite signal
Operating Temperature	-40° to 185° F (-40° to 85° C)	-40° to 185° F (-40° to 85° C)
Shock / Vibration	100 g for 6 ms / 10 to 500 Hz at 10 g	100 g for 6 ms / 10 to 2000 Hz at 15 g
Thermal Coefficient	±0.01%/°C max	±0.01%/°C max

#### Electrical Connection

Code 1 (wire)	Code 2 (pin)	Code 3 (pin)	Code 4 (pin)	Signal
red	A	1	1	input, V+
black	B	2	2	ground, common, V-, S-
white	C	3	3	output, signal, S+

### Electrical Outputs – Low-Level Bridge

LOW-LEVEL BRIDGE (B Circuit / Strain Gage Compatible)

Item	Value
Supply Voltage	7 to 40 VDC max
Supply Current	20 mA max
Reverse Polarity Protection	yes
Increasing/Decreasing Output Options	yes
Output Signal	0.2 mV/V to 3.75 mV/V at 24 VDC supply voltage
Zero Adjust	0% to 100% of range
Span Adjust	see <i>Typical Outputs</i> table below
Independent Linearity Error	±0.25% max per VRCI-P-100A
Insulation Resistance	1000 Mohms min
Resolution	infinite signal
Operating Temperature	-40° to 185° F (-40° to 85° C)
Thermal Coefficient	±0.01%/°C max

#### Typical Outputs

Supply Voltage (VDC)	Min Span (mV)	Max Span (mV)	Sensitivity Range (mV/V)
7	4.92	20.5	0.7 to 2.928
12	4.92	41	0.41 to 3.42
24	4.92	90	0.205 to 3.75

#### Electrical Connection

Code 1 (wire)	Code 2 (pin)	Code 3 (pin)	Code 4 (pin)	Signal
red	A	1	1	V+
black	B	2	2	V-
white	C	3	3	S+
green	D	4	4	S-, ground

**Electrical Outputs – Voltage Conditioner**

VOLTAGE CONDITIONER (unregulated input)

Item	Single-Ended (0–5 VDC, 0–10 VDC, Etc.)	Differential (±5 VDC, ±10 VDC, Etc.)
Supply Voltage	7 to 40 VDC for 0–5 VDC 12 to 40 VDC for 0–10 VDC	12 to 40 VDC for ±5 VDC 22 to 40 VDC for ±10 VDC
Supply Current	20 mA max	20 mA max
Reverse Polarity Protection	yes	yes
Increasing/Decreasing Output Options	yes	yes
Output Signal (User Adjustable)	0–5 VDC, 0–10 VDC, 5–0 VDC, 10–0 VDC, and user-adjustable values	±5 VDC, ±10 VDC, and user-adjustable values
Zero Adjust	0% to 100% of range	0% to 100% of range
Span Adjust	20% to 65% at 7 VDC supply 5% to 95% at 40 VDC supply	20% to 65% at 7 VDC supply 5% to 95% at 40 VDC supply
Independent Linearity Error	±0.25% max per VRCL–P–100A	±0.25% max per VRCL–P–100A
Insulation Resistance	1000 Mohms min	1000 Mohms min
Resolution	infinite signal	infinite signal
Operating Temperature	–40° to 185° F (–40° to 85° C)	–40° to 185° F (–40° to 85° C)
Thermal Coefficient	±0.01%/°C max	±0.01%/°C max

Electrical Connection

Code 1 (wire)	Code 2 (pin)	Code 3 (pin)	Code 4 (pin)	Signal
red	A	1	1	V+
black	B	2	2	V–
white	C	3	3	S+
green	D	4	4	S–, ground

**Electrical Outputs – 4–20 mA**

4–20 mA (2-wire current transmitter)

Item	Value
Supply Voltage	12 to 40 VDC with reverse polarity protection
Supply Current	35 mA max
Output Signal	4–20 mA (user adjustable) with increasing and decreasing output options
Zero Adjust	0 to 5% of range
Span Adjust	50 to 100% of range
Independent Linearity Error	±0.25% max per VRCL–P–100A
Insulation Resistance	1000 Mohms min at 750 Vrms
Resolution	infinite signal
Operating Temperature	–40° to 185° F (–40° to 85° C)
Thermal Coefficient	±0.01%/°C max

*A Note on Load Resistance in 4–20 mA Current Loops* – The maximum load resistance or loop resistance is the maximum resistance of all the loads that are connected in series with the circuit. This includes all instrumentation equipment such as power supply and multimeter. The maximum load resistance (RLmax) depends on 2 factors: the voltage supply (Vps) and the maximum loop current (Iloop). For the Series 6 4–20 mA circuit,  $RL_{max} = (V_{ps} - 11.6) / I_{loop}$

Example:

Vps = 24 V  
Iloop = 30 mA  
 $RL_{max} = (24 - 11.6) / 30 = 0.413 \text{ Kohms}$

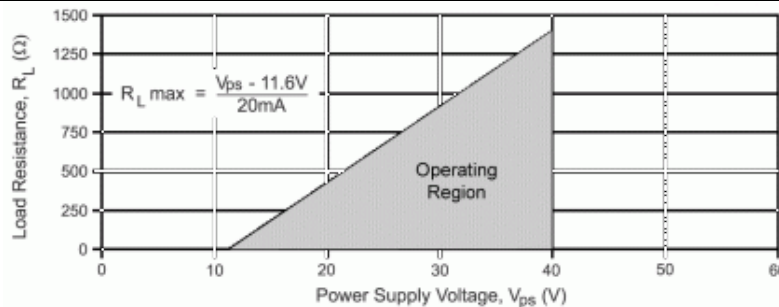

Electrical Connection

Code 1 (wire)	Code 2 (pin)	Code 3 (pin)	Code 4 (pin)	Signal
red	A	1	1	V+
black	B	2	2	V–

**Electrical Outputs – Digital**

DIGITAL (incremental optical encoder (quadrature))

Item	Standard Resolution	High Resolution
Power Requirement	5 ±0.50 VDC	5 to 26 VDC
Supply Current	29 mA max at 5 VDC	35 mA max at 5 VDC
Logic Output	open collector and 3.3 Kohm pull-up resistor (TTL)	open collector with Schmitt trigger and 10 Kohm pull-up resistor (push-pull differential line driver)
Power Consumption		150 mW max, 16 mA sink current at 0.40 VDC

	145 mW max, 3.86 mA sink current at 0.40 VDC	
Travel: Electrical, Mechanical	360° continuous	360° continuous
Mechanical Life	100 million shaft revolutions min	100 million shaft revolutions min
Resolution	1200 quadrature pulses per revolution	8192 quadrature pulses per revolution
Output	2-bit (quadrature) code, A leads B by 90° w/CW	2-bit (quadrature) code, A leads B by 90° w/CW
Operating Temperature	14° to 185° F (-10° to 85° C)	-4° to 212° F (-20° to 100° C)
Shock / Vibration	100 g for 6 ms / 5 to 2000 Hz, 20 g	50 g for 11 ms / 50 to 500 Hz at 20 g

Electrical Connection

Resolution	Pin/Wire Assignment					
Standard	Sensor Pin	Code 1 (wire)	Code 2 (pin)	Code 3 (pin)	Code 4 (pin)	Signal
	-	orange	A	1	1	+5 VDC
	-	white/orange	B	2	2	ground
	-	blue	C	3	3	channel A
	-	white/blue	D	4	4	channel B
High	Sensor Pin	Code 1 (wire)	Code 2 (pin)	Code 3 (pin)	Code 4 (pin)	Signal
	1	red	A	1	1	common
	2	gray	B	2	2	+VDC
	3	brown	C	-	3	Z
	4	-	-	-	-	-
	5	blue	D	4	4	B
	6	-	-	-	-	-
	7	yellow	E	3	5	A
	8	-	-	-	-	-
	9	-	-	-	-	-
10	black	F	-	6	case	

Nominal Resolution by Model Number (Digital)

Model	inches	mm	Standard Resolution#		High Resolution#	
			pulses/in	pulses/mm	pulses/in	pulses/mm
60-35	21.25	540	278	11	1895	75
61-45	30.00	762	197	8	1344	53
62-55	42.50	1080	140	6	954	37.6
62-60	85.00	2159	140	6	954	37.6

# after quadrature decode by user

Other Specifications

Case/Drum Materials	precision-machined, anodized 2024 aluminum
Displacement Cable	0.018-inch (0.46-mm) dia., 7-by-7 stranded stainless steel, 40-lb (177-N) min breaking strength
Displacement Cable Hardware	1 each of 300196 loop sleeve, 300292 copper sleeve, 300688 ball-end plug, 300495 pull ring, 160026 brass swivel, and 301003 nickel swivel: all items provided uncrimped
Nominal Mass	Model 60: 6 oz (170 g), Model 61: 8 oz (227 g), Model 62: 11 oz (312 g)
Environmental Sealing	NEMA 4 / IP 66

Model Numbers and Cable Tension

Model	Range		Nominal Displacement Cable Tension Range (Full Retraction to Full Extraction)							
	inches	mm	Opt 5		Opt 6		Opt 7		Opt 8	
			oz.	N	oz.	N	oz.	N	oz.	N
60-11	4.00	102	<b>4 to 8</b>	<b>1 to 2</b>	5 to 12	1 to 4	12 to 20	3 to 6	28 to 55	7 to 16
60-25	13.50	343	<b>7 to 20</b>	<b>2 to 6</b>	12 to 28	3 to 8	18 to 53	5 to 15	30 to 134	8 to 37
60-35	21.25	540	5 to 12	1 to 3	<b>7 to 19</b>	<b>2 to 5</b>	12 to 33	3 to 9	14 to 79	4 to 22
61-45	30.00	762	-	-	5 to 12	1 to 3	<b>8 to 23</b>	<b>2 to 6</b>	9 to 60	3 to 17
62-55	42.50	1080	-	-	4 to 14	1 to 4	<b>7 to 17</b>	<b>2 to 5</b>	8 to 41	2 to 11
62-60	85.00	2159	-	-	-	-	-	-	15 to 50	4 to 14

**Bolded** entries are standard cable tension.

Displacement Cable Maximum Acceleration by Model Number

Model	Max Cable Acceleration (g's)			
	Opt. 5	Opt. 6	Opt. 7	Opt. 8
60-11	8	10	23	69
60-25	55	65	109	165
60-35	30	40	75	70
61-45	-	56	72	95
62-55	-	18	31	45
62-60	-	-	-	15

Ordering Codes

Order Code Format	Description
ab-cd-efgh	position transducer
Example: 60-11-6281 (Model 60-11 (Series 60, 4-in (102-mm) range), cable tension: Opt. 6, bridge circuit, base: big foot (60/61), and flying leads)	

Variable	Value	Description
ab-cd	-	size and range (model number)
e	5	cable tension: Opt. 5
	6	cable tension: Opt. 6

	7	cable tension: Opt. 7
	8	cable tension: Opt. 8
f	1	voltage divider
	2	bridge circuit – factory preset to 0–10 mV (increasing output)
	3	bridge circuit – factory preset to 10–0 mV (decreasing output)
	4	voltage conditioner – factory preset to 0–5 VDC (increasing output)
	5	voltage conditioner – factory preset to 5–0 VDC (decreasing output)
	6	4–20 mA (increasing output)
	7	20–4 mA (decreasing output)
	8	digital (standard resolution, quadrature)
	9	digital (high resolution, quadrature)
g	1	base: mounting disk (6 ); pn 160040–1
	2	base: standard (60); pn 160015–1
	3	base: standard (61); pn 160015–3
	4	base: standard (62); pn 160015–5
	5	base: universal (60); pn 160030–1
	6	base: universal (61); pn 160030–3
	7	base: universal (62); pn 160030–5
	8	base: big foot (60/61); pn 160015–13
	9	base: big foot (62); pn 160015–15
	A	base: h (60); pn 160015–G1
B	base: universal (miniature) (60); pn 300460	
h	1	FOR f = 1 to 8 > electrical termination: flying leads (4–conductor white Teflon cable with 22 AWG flying leads, 60–in (1524–mm) min length, 0.163 (4.14) nominal diameter) FOR f = 9 > electrical termination: flying leads (6–conductor white Teflon cable with 24 AWG flying leads, 60–in (1524–mm) min length, 0.185 (4.70) nominal diameter)
	2	electrical termination: MS3106A–14S–6P sealed bulkhead electrical connector (per MIL–C–5015) and mating 300853 electrical connector (MS3106F–14S–6S)
	3	electrical termination: Lemo EGG.0B.304.CLL bulkhead electrical connector and mating Lemo FGG.0B.304.CLAD52 electrical connector
	4	electrical termination: DIN 45326 sealed (per IP68) bulkhead electrical connector and mating electrical connector

Drawing

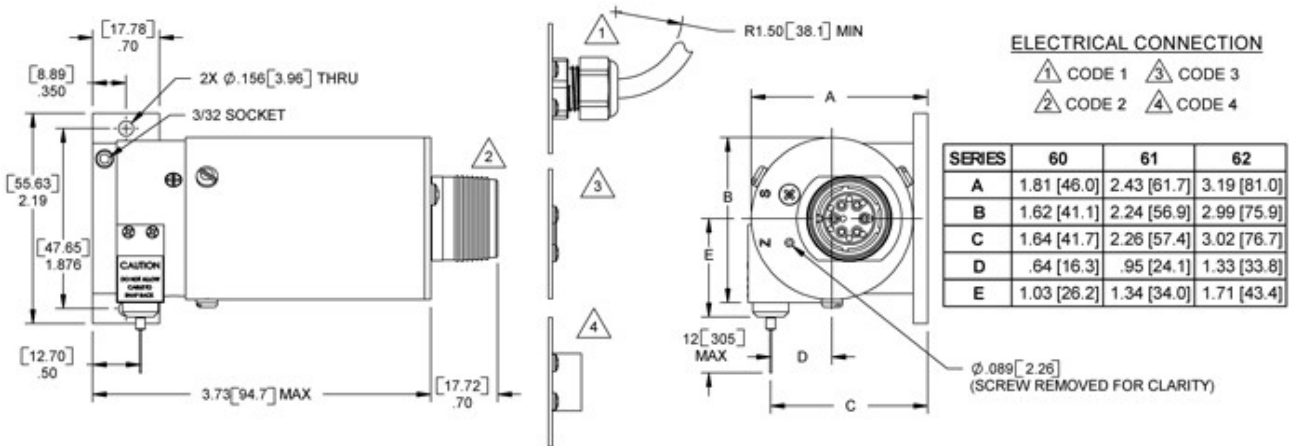

Related Products

Part Number	Description
160001–01	installation kit

For crimping of hardware to displacement cable, consider the [160001–01 installation kit](#).

Need something not shown? Complete a [Custom Solution Request](#).

All dimensions are REFERENCE and are in inches [mm] • Document number: S021K(040627)